

Installation instructions MultiChiller

The following text contains information on the requirements for installing our MultiChillers with flammable refrigerants. This ensures operational safety on site.

The MultiChiller is designed for indoor installation. The entire refrigeration circuit is located in a ventilated housing (in accordance with DIN EN 378-1). The system is designed to be technically sealed in the long term. The housing is sufficiently mechanically ventilated so that an explosive atmosphere cannot occur in the event of a leak. No zoning is required.

Further information in the operating instructions: Analysing and assessing hazards and risks.

The refrigerants R290, R1270 and R600a are heavier than air. The safety extraction system of the MultiChiller must be connected via an antistatic hose and led to the open air. Longer lengths require recalculation and, if necessary, support from a ventilation duct. The following information and the next illustration must be observed for the exhaust point:

- Floor inlets, ventilation openings, floor flaps or similar openings in the immediate vicinity of the blowout point must not be present. We recommend a distance of at least 5 m.
- Floor recesses and depressions in which blown-out refrigerant can collect are not permitted.
- Escaping refrigerant must not enter neighbouring areas through openings (e.g. ventilation openings for fresh air, door openings, etc.). Air routing through the installation room into an area where people are present is not permitted.
- There must be no ignition sources at the outlet point of the MultiChiller extraction system.
- Sufficient ventilation must be provided for the installation room in the form of mechanical ventilation or a sufficiently large area to the outside. In the case of mechanical ventilation, the supply and exhaust air must be sufficiently separated from each other so that no exhaust air can be drawn in and the installation room is evenly ventilated.
- No hydrocarbon compounds may be present in the installation room, e.g. in solvents, adhesives, aerosol cans.
- There should be no heavy dust accumulation in the installation room.
- Sufficient ventilation must be provided for hot work such as welding and soldering.

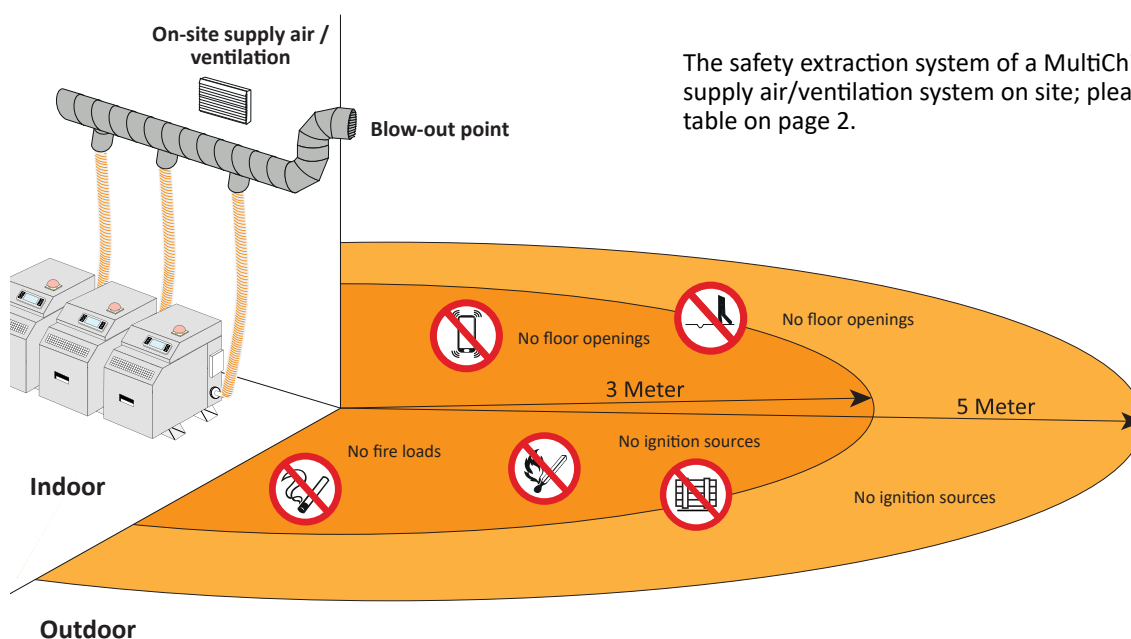

The safety extraction system of a MultiChiller requires a supply air/ventilation system on site; please refer to the table on page 2.

Installation instructions MultiChiller

MultiChiller model	Flow rate [m ³ /h]	Max. pressure loss for re- quired on-site supply air [Pa]	Max. length of ex- haust air hose DN 50 [m]*
MCS XX-2 E (HP)	19	100	20
MCS XX-4 E (HP)	28	100	20
MCS XX-6 E (HP)	42	100	20
MCM / MCL XX-8 E (HP)	52	100	20
MCM / MCL XX-10 E (HP)	70	100	15
MCM / MCL XX-12 E (HP)	77	100	10

* The hose should be laid as straight as possible. Three 90° bends and three 60° bends are assumed over the entire length.

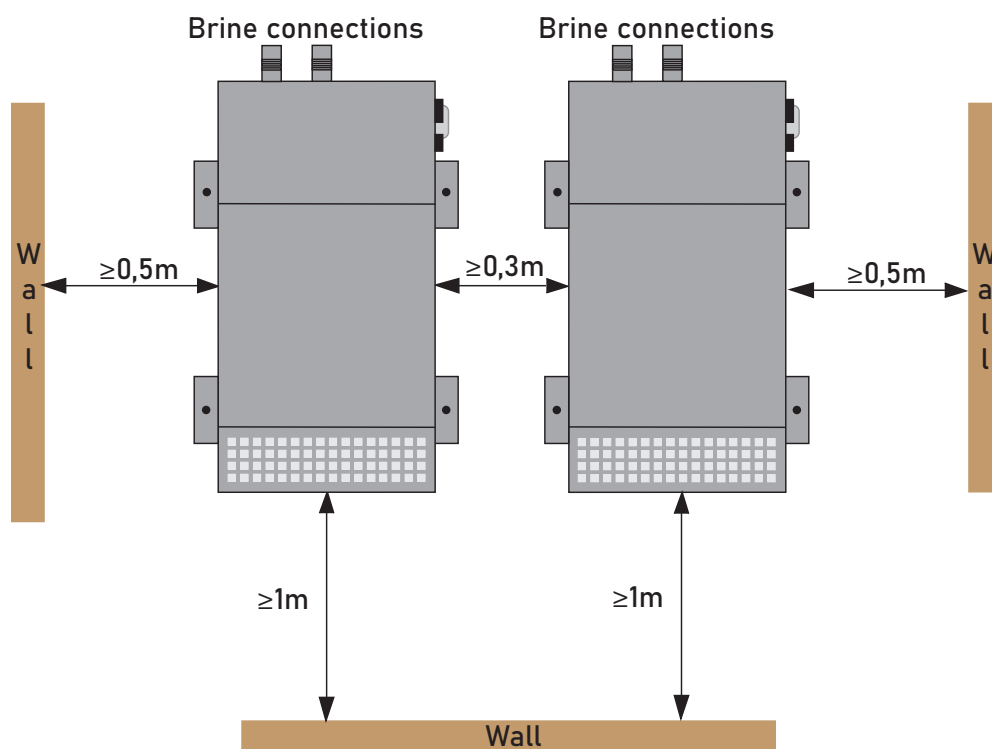

Smoking and open flames around the blow-out point are not permitted. There must be no sources of ignition. The limit values specified in the table below must not be exceeded.

Maximum permissible surface temperatures and concentrations of refrigerants

Refrigerant	Maximum surface temperature [°C]	Maximum refrigerant concentrations at potential ignition sources [kg/m ³]
R290	370	0,019
R1270	355	0,023
R600a	360	0,0215

Installation instructions MultiChiller

The following safety systems are used:

- Two-stage ATEX gas sensor for the flammable refrigerant and fan for conveying escaping flammable gas to the outside as soon as a concentration of 2000 ppm is exceeded in the housing. Safe discharge must be possible.

Setting ATEX gas sensor MultiChiller

Switching stages	Action	Setting value of the ATEX gas sensor
1	The fan safely conveys any escaping refrigerant to the outside and switches the fan off again when the temperature falls below the set value. MultiChiller remains active.	2000
2	The refrigeration machine is switched off. The fan safely transports any escaping refrigerant to the outside. Once the set value is exceeded, the electrical voltage to the MultiChiller is restored. The MultiChiller is reactivated once the set value is exceeded. The ATEX gas sensor remains active at all times.	4000

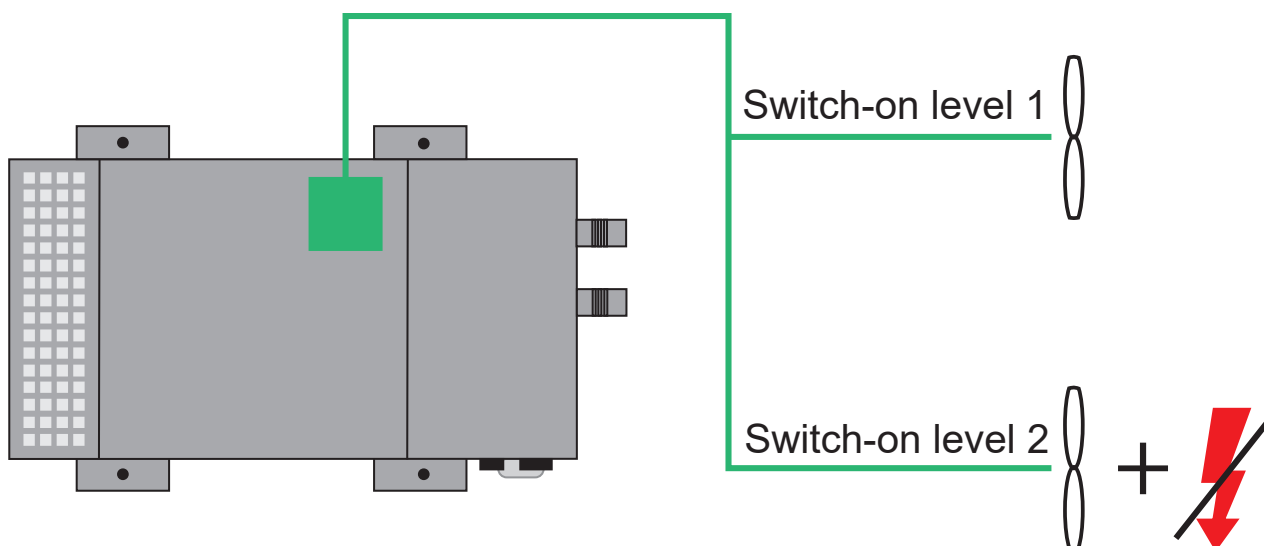

The MultiChiller is also to be regarded as „energised“ when the gas sensor is triggered!

If you have any questions, please contact Futron GmbH phone: +49 (0) 37 65 / 38 03 - 0.